



Assistant Professor

Civil Engg. Dept./ College of Engg./ Mosul University



A non-linear, layered, finite element model for predicting the time dependent behavior of reinforced concrete slabs under sustained transverse loading is presented. The effects of biaxial creep and shrinkage are accounted for using short form of creep and shrinkage prediction model B3 for structures of medium sensitivity. The layered approach is used to represent the steel reinforcement and discretize the concrete slab through the thickness. The reinforcement steel is represented as a smeared layer of equivalent thickness with uniaxial strength and rigidity properties. Elastic perfect plastic approaches have been employed to model the compressive behavior of the concrete. The yield condition is formulated in terms of the first two-stress invariant. The movement of the subsequent loading surfaces is controlled by the hardening rule, which is extrapolated from the uniaxial stress-strain relationship defined by a parabolic function. concrete crushing is a strain controlled phenomenon. Which is monitored by a fracture surface similar to the yield surface. A smeared fixed crack approach is used to model the behavior of the cracked concrete, coupled with a tensile strength criterion to predict crack initiation. Several examples for which experimental results are available are analyzed, using the proposed model. The comparison showed good agreement.

Creep and Shrinkage, Nonlinear Analysis Reinforced Concrete Slabs, Time Dependent analysis.

تحليل العناصر المحددة اللاخطي للسقوف الخرسانية المسلحة

للزحف والانكماش

ماجد علي الجرهمه

أياد امجد عبد الرزاق

مدرس

أستاذ مساعد

مساعد

جامعة الموصل- كلية الهندسة /قسم الهندسة المدنية

### الخلاصة

استعملت طريقة العناصر المحددة لبحث أداء البلاطات الخرسانية المسلحة المعتمد على الزمن سواء كانت هذه الأحمال ثابتة أو متغيرة. مثل تأثير الزحف والانكماش اعتماداً على النموذج المختصر B3 لتقدير الزحف والانكماش للمنشآت معتدلة الحساسية ، يستند البرنامج المستخدم في هذا البحث الى صياغة العناصر المحددة ، حيث يحتوي كل عنصر على ثمان عقد ، وكل عقدة تمتلك خمس درجات للحرية. استعمل أسلوب تقسيم السمك إلى طبقات لتمثيل سلوك الخرسانة خلال السمك، استخدم أسلوب الطبقات لتمثيل حديد التسليح كطبقة ضمن طبقات الخرسانة ، مع استخدام نظام الإحداثيات المعدلة .

سلوك الخرسانة بعد الخضوع في حالة الانضغاط كمادة مرنة تامة للدونه أو كمادة مرنة مع انفعالات لدنه متصلده شروط الخضوع عبر عنها بدلالة أول متغيرين للإجهاد . حركة سطوح التحميل حكمت بقاعد، التصلب التي تتحدد من علاقة الإجهاد -الانفعال الأحادي المحور والمعبر عنها بدلالة القطع المكافئ. سحق الخرسانة هي ظاهرة محكومة بالانفعال ومنظمة بسطح سحق يشبه سطح الخضوع .

استخدم أسلوب الشق الثابت لتمثيل سلوك الخرسانة المتشقة مع شرط الشد للتنبؤ بحدوث الشق .  
Received 15 July, 2007 Accepted 12 Nov, 2007  
بنظر الاعتبار تأثير حديد التسليح اعتبر كمادة مرنة تامة للدونه مع

. اعتبر سلوك حديد التسليح متشابه تحت تأثير قوى الشد والانضغاط .

أمثله ذات نتائج عملية منشوره باستعمال الأسلوب المقترح و أظهرت توافقاً جيداً مع النتائج العددية.

### Notation

Ae	Element area
B	Strain-displacement matrix
B <sub>b</sub>	Bending strain-displacement matrix
B <sub>s</sub>	Transverse shear strain-displacement matrix
D	Elasticity matrix
D <sub>b</sub>	Flexural rigidities
D <sub>s</sub>	Shear rigidities
E	Young's modulus
F	Percent fines by weight

$f'_c$	Concrete cylinder compressive strength
$f'_{c\max}$	Maximum compressive strength in the direction parallel to the crack direction.
H	Ambient humidity or hardening parameter
K	Stiffness matrix
$K_b$	Bending stiffness matrix
$K_s$	Transverse shear stiffness matrix
$M_x, M_y, M_{xy}$	Generalized stress resultants (moments)
$Q_x, Q_y$	Generalized stress resultants (shear forces)
S	Slump
t	Time in days
w, $d_i$	Displacements
$\gamma_{xz}, \gamma_{yz}$	Transverse shear strains in Cartesian coordinate system.
$\epsilon_b$	Bending strain tensor
$\epsilon_s$	Transverse shear strain tensor.
$\theta_{xi}, \theta_{yi}$	Rotations about x and y axes, respectively.
$\nu$	Poisson's ratio

## II

The failure of a high parabolic (HP) gable shell roof in Virginia, seven years after its construction [1] underlines the importance of the application of realistic and rational models, load conditions and methods for the analysis and design of such structures. To guarantee the serviceability of any structure throughout its useful period, it may be important to perform an analysis to obtain the response history during that period incorporating inelastic and time-dependent effects. Moreover, for the correct estimation of safety against failure, an ultimate analysis becomes mandatory. The development of the finite element

method with the simultaneous application of increasingly efficient and sophisticated digital computers in recent years has resulted a significant progress in the investigation of the behavior of reinforced concrete structures for time dependent effects such as creep, shrinkage, temperature changes and load history. Wei Yang et al [2] developed a test method to assess the potential of shrinkage cracking and developed a theoretical model to predict cracking and a method for evaluation of a non expansive shrinkage reducing admixture.

Robert Geist [3] presented a technical note for the fundamental computation for the foundation of an algorithm used to predict the creep behavior of material under stress. The model class employs four components with matched derivatives to represent the traditional primary, secondary, and tertiary stage of creep.

Sandeep Baweja et al [4] showed how the mechanism of elastic composite materials can be adopted to predict the basic creep of concrete with aging due to hydration. The prediction is made on the basis of the given composition of concrete the elastic constants of the aggregate and the aging viscoelastic properties of the Portland cement estimated by Dvorak's transformation field analysis.

Amin Ghali and Azarnejad [5] presented a summary of methods of analysis to predict the immediate and time dependent strains in reinforced concrete sections with or without prestressing.

AL-Naimi [6] adopted three-dimensional computational models of eight and twenty node elements for the idealization of the concrete brick element by assuming perfect bond with imbedded steel. Non-linear material and time - dependent effects have been included in this analysis.

Abdul-Razzak and al Jurmaa [7] presented effect of mix property on time dependent behavior of reinforced concrete slabs, the effects of biaxial creep and shrinkage are considering by using the provisions of ACI committee.

Abdul-Razzak and Al Jurmaa [8] presented a finite element model for predicting the time dependent behavior of reinforced concrete slab under sustained transverse loading , They included the nonlinear effect in this analysis.

## **Basic theory**

The variation of the displacement and rotation fields over a Mindlin plate element is given by the following expression [9].

$$[W, \theta_x, \theta_y]^T = \sum_{i=1}^n N_i d_i \quad (1)$$

where  $N_i$  the shape function for node ( i ) in the natural coordinate .

The plate curvature-displacement and shear strain-displacement relations are then written as:

$$\varepsilon_b = \sum_{i=1}^n B_{bi} d_i \quad , \quad \varepsilon_s = \sum_{i=1}^n B_{si} d_i \quad (2)$$

The moment-curvature and shear force-shear strain relationships are given as:

$$[M_x, M_y, M_{xy}]^T = D_b \varepsilon_b, \quad [Q_x, Q_y]^T = D_s \varepsilon_s \quad (3)$$

The stiffness matrix (Kij) contributions from the bending and shear relations can be written as:

$$K_{bij}^e = \int_{Ae} B_{bi}^T D_b B_{bj} dA \quad , \quad K_{sij}^e = \int_{Ae} B_{si}^T D_s B_{sj} dA \quad (4)$$



Mechanisms of creep and shrinkage in concrete are not fully understood and the prediction of creep and shrinkage behavior in concrete is imprecise at best. Creep and shrinkage are often treated as separate and independent phenomena. In actuality the effect of creep is significantly greater when accompanied by shrinkage e.g., drying creep is the additional creep resulting from drying of concrete.

Over the last two decades , number of predictive models have been developed to take into account the interdependence of creep and shrinkage [10].

In the time dependent analysis of reinforced concrete, it is convenient to represent creep of concrete by using a creep coefficient, defined as the ratio of creep strain to elastic (instantaneous) strain. This presumes that the creep strain is linearly related to the applied stress through the elastic term. The assumption of linearity of creep must be made for the principle of superposition to be used in a time dependent analysis considering a multi- pulse process. This condition

is generally met when the applied stress is about 50% less than the concrete strength [10,11].

The long term creep strains of concrete under service stress are typically 2 to 6 times the short –term elastic strains, and even short -term deformation of about 10 minute duration comprises 25-50 % of the creep. Thus, consideration of creep is important for realistic analysis of concrete structures [11, 12].The present study considered the B3 model as conclusion of too many research that high accuracy for determined true behavior of concrete in creep and shrinkage [13].



The prediction of material parameters of the present model from strength and composition is restricted to Portland cement concrete with the following parameter ranges: [13]

$$17 \text{ MPa} < f'_c < 70 \text{ MPa} \quad (5)$$

$$160 \text{ kg/m}^3 < c < 720 \text{ kg / m}^3 \quad (6)$$

$$0.35 < w/c < 0.85 \quad 2.5 < a/c < 13.5 \quad (7)$$

where w/c water / cement ratio , c is cement content .

(The numbers 0.85 and 720 kg / m<sup>3</sup> are, of course, outside the range of good concerts in today's practice)

The average compliance function for the cross section of a long member, representing the sum of the instantaneous deformation ,the combined basic creep and the additional creep due to drying ,is expressed as:

$$J(t-t') = q_1 + C_0(t,t') + Cd(t,t',t_0) \quad (8)$$

where q<sub>1</sub> is instantaneous deformation

$C_0(t,t')$  basic creep

$Cd(t,t',t_0)$  secondary creep due to drying .

### Basic creep

Based on the log-double power law [14], the basic creep compliance function is given as :

$$C_0(t, t') = q_0 \ln\{1 + \psi[(t')^{-m} + \alpha](t - t')^n\} \quad (9)$$

In which  $m=0.5$ ,  $n=0.1$ ,  $\alpha=0.001$ ,  $\psi = 0.3$ ,  $q_0$  initial deformation.

### Mean shrinkage and creep of cross section at drying

The initial relative humidity in the pores of concrete is 100%. Subsequent exposure to environment causes a long -term drying process, which causes shrinkage and additional creep.

### Shrinkage

Mean shrinkage strain in the cross section. [13]

$$\varepsilon_{sh}(t, t_0) = -\varepsilon_{sh\infty}.kh.S(t) \quad (10)$$

$S(t)$  Time dependent function.

$$S(t) = \tanh \sqrt{\frac{t - t_0}{\tau_{sh}}} \quad (11)$$

$(kh)$  Humidity Dependence.

$$\begin{aligned} kh &= 1 - h^3 && \text{for } h \leq 0.98 \\ &= -0.2 && \text{for } h=1 \text{ (swelling in water )} \end{aligned} \quad (12)$$

Linear interpolation for  $0.98 \leq h \leq 1$  ,

where  $h$  is humidity ,  $k$  factor depend on cement type. [13]

### Size Dependence:

$$\tau_{sh} = 4.9 D^2 \quad (D \text{ in cm}) \quad (13)$$

where  $D = 2 v/s$  = effective cross -section thickness .

where  $v/s$  is ratio of volume to surface area of member. [13]

### Additional Creep due to Drying (drying creep)

$$Cd(t, t', t_0) = q5[e^{-3H(t)} - e^{-3H(t')}]^{0.5} \quad \text{for } t' \geq t_0 \quad (14)$$

in which

$$H(t) = 1 - (1 - h) S(t) \quad (15)$$

### Parameter prediction based on strength and water content of concrete

Some formulae that follow are valid only in certain dimension. [13]

**E**

$$q_0 = 2408 f'_c{}^{-0.5} ; \quad q_1 = 0.6 \times 10^6 / E_{28} ; \quad E_{28} = 4743 \sqrt{f'_c} \quad (16)$$

### Shrinkage:

$$\varepsilon_{sh}^\infty = \alpha_1 \alpha_2 [0.019 w^{2.1} (f'_c)^{-0.28} + 270] \quad (\text{in } 10^{-6}) \quad (17)$$

$$\alpha_1 = 1.0 \quad \text{for type I cement}$$

$$\alpha_1 = 0.85 \quad \text{for type II cement} \quad (18)$$

$$\alpha_1 = 1.1 \quad \text{for type III cement}$$

$$\alpha_2 = 0.75 \quad \text{for steam - cured concrete}$$

$$\alpha_2 = 1.0 \quad \text{for concrete cured in water or 100% relative Humidity}$$



$$\alpha_2 = 1.2 \quad \text{for concrete sealed during curing} \quad (19)$$



$$q_5 = 6000(f'c)^{-1} \quad (20)$$

The present model B3 have typical shrinkage and creep curves show in Fig(1).

### Material modelling

Based on the flow theory of plasticity, the nonlinear compressive behavior of concrete is modeled. Adopting Kupfer's results [15], the yield condition for the slabs can be written in terms of the stress components as:

$$f(\sigma) = \{1.355[(\sigma_x^2 + \sigma_y^2 - \sigma_x\sigma_y) + 3(\tau_{xy}^2 + \tau_{xz}^2 + \tau_{yz}^2)] + 0.355\sigma_o(\sigma_x + \sigma_y)\}^{1/2} = \sigma_o \quad (21)$$

where ( $\sigma_o$ ) is the equivalent effective strength taken as compressive strength ( $f_c^\circ$ ) obtained from uniaxial test. Both perfect-plastic and strain hardening plasticity approaches are employed which are illustrated, for one dimension, in Fig. (2).

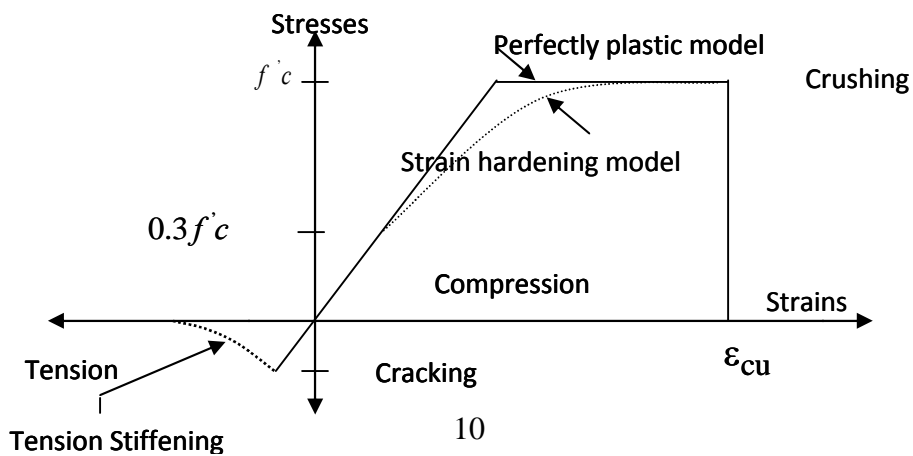
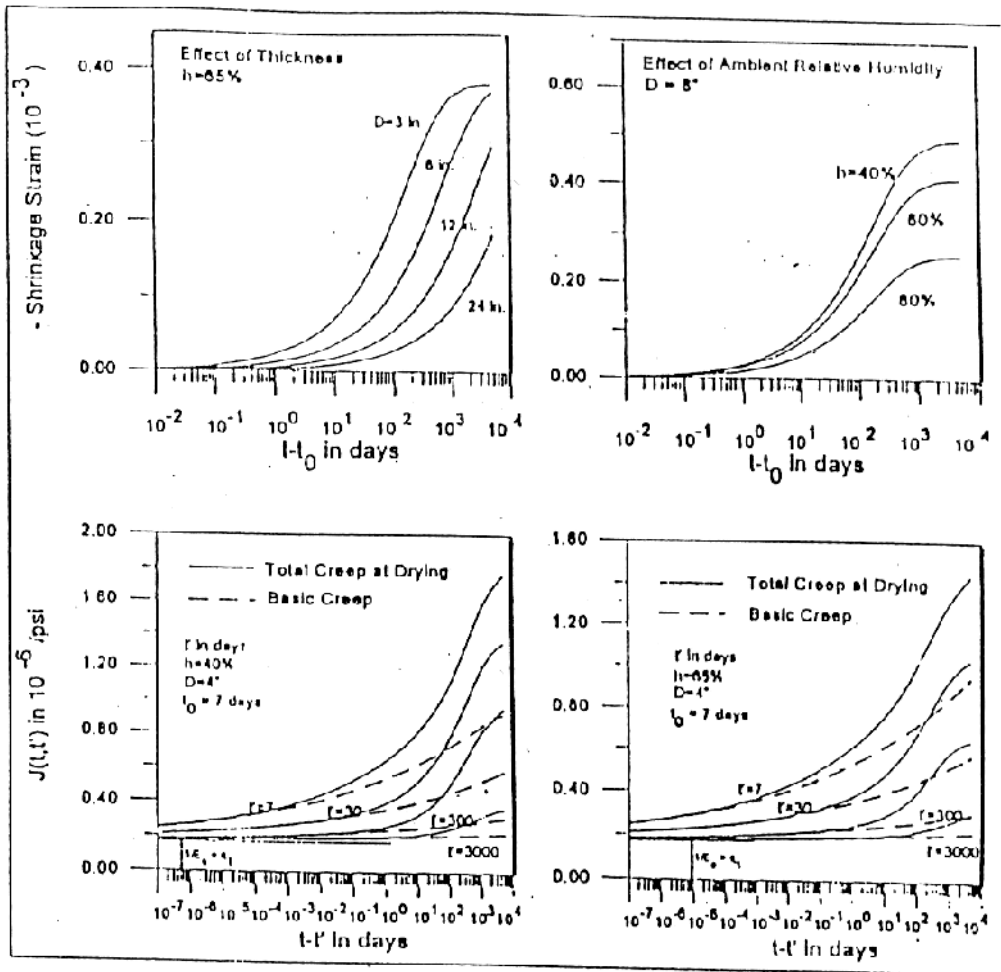



The crushing type of concrete is a strain-controlled phenomenon. A simple way is used by converting the yield criterion in stresses into the yield criterion directly in terms of the strain, thus crushing condition can be expressed in terms of the total strain components as:

$$1.355 [(\epsilon_x^2 + \epsilon_y^2 - \epsilon_x \epsilon_y) + 0.75(\gamma_{xy}^2 + \gamma_{xz}^2 + \gamma_{yz}^2)] + 0.355 \epsilon_u (\epsilon_x + \epsilon_y) = \epsilon_u^2 \quad (22)$$

When Equation (22) is satisfied, the strain ( $\epsilon_u$ ) reaches the crushing surface, and the concrete is assumed to lose all its characteristics of strength and stiffness.

The response of concrete in tension is assumed to be linearly elastic until the fracture surface is reached. Cracks are assumed to form in planes perpendicular to the direction of maximum principal tensile stress if the maximum stress reaches the specified concrete tensile strength. After cracking has occurred, a gradual release of the concrete stress component normal to cracked plane is adopted according to a tension-stiffening diagram illustrated in Fig. (3). The process of loading and unloading of cracked concrete is also shown in Fig. (3). A reduced shear modulus taken as a function of the current tensile strain is used to simulate aggregate interlock and dowel action.

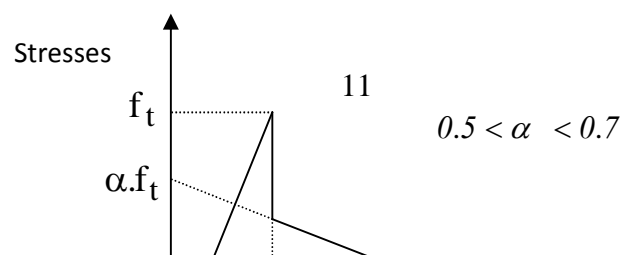

**Fig.(3) Tension stiffening in concrete after cracking.[15]**

The tensile cracks produces damage to concrete with the transverse strain having a degrading effect not only on the compressive strength but also in the compressive stiffness, so that the concrete in this case become softer and weaker than that in a standard cylinder test. In the present study the relationship suggested by Belarbi and Hsu [16] is adopted,

$$f'_{c \max} = \frac{0.9f'_c}{\sqrt{1 + 400 \varepsilon_1}} \quad (23)$$

where  $f'_c$  is the concrete cylinder compressive strength and  $(\varepsilon_1)$  is the average principal tensile strain of concrete in direction (1).

Steel reinforcement is modeled by considering the steel bars as layers of equivalent thickness. Each steel layer exhibits uniaxial response, having strength

and stiffness characteristics in the bar direction. A bilinear idealization is adopted in order to model the elasto-plastic stress-strain relationships.

An incremental /iterative Newton-Raphson method is employed in order to trace the response of the structure through the loading history.

## Numerical examples

### Example one

A one way slab, under uniform load given by reference [17] is shown in Fig (4). The material properties are given in table (1). Taking advantage of symmetry only one quarter of the slab is considered and idealized by 16 slab elements. Results of load deflection curves are shown in Fig (5). Good agreement is obtained by the proposed elements compared with the experimental results.

Table 1

$b$	$E_c$	$f'_c$	$v_c$	$f'_t$	$\alpha$	$\epsilon_m$	$E_y$	$E_z$	$E_x$
0.304	31	31	0.017	3	0	0	9	0	0

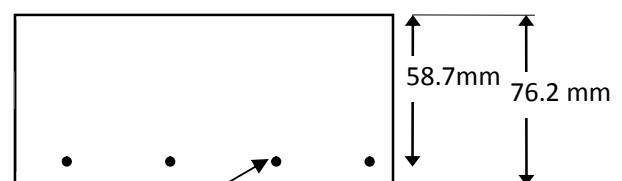
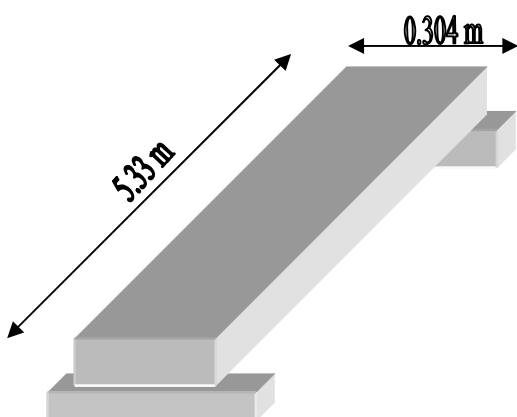

4Φ10mm

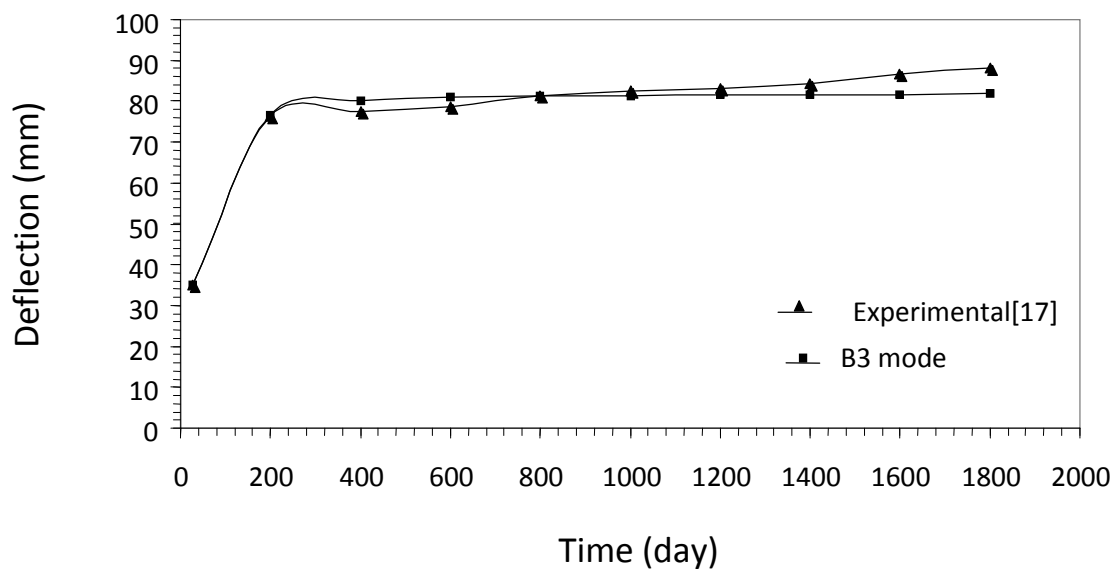

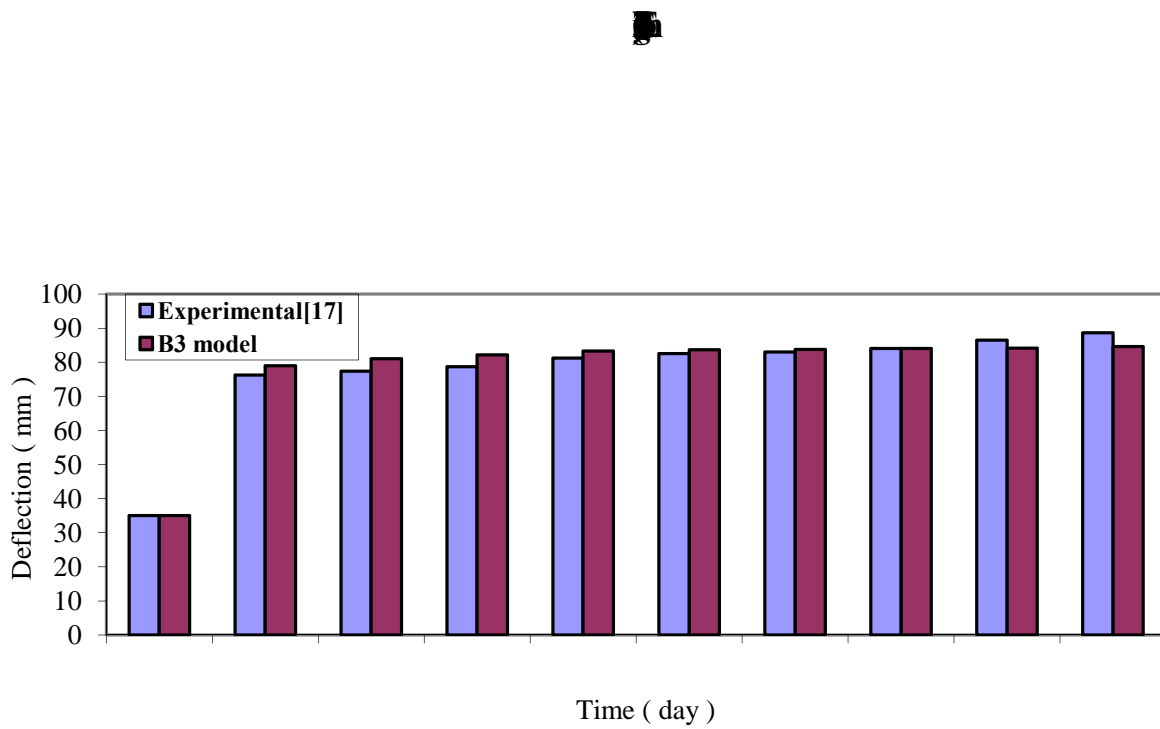

**Fig.(4b):Variation of deflection with time**

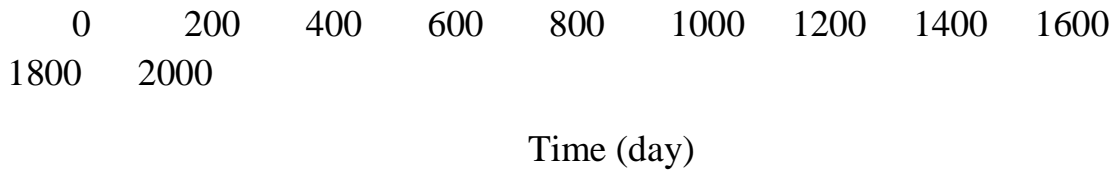

### Example two

A square slab supported at the four corners and subjected to uniform load is shown in Fig (7). This example is analyzed by reference [18]. The material properties are given Taking advantage of symmetry only one quarter of the slab is considered and idealized by 16 slab elements. Results of load deflection curves are shown in Fig (8), Variation of compressive strength and modulus of elasticity with time are shown in Fig (9) and Fig (10) respectively.

Good agreement is obtained by the proposed models compared with the experimental results.

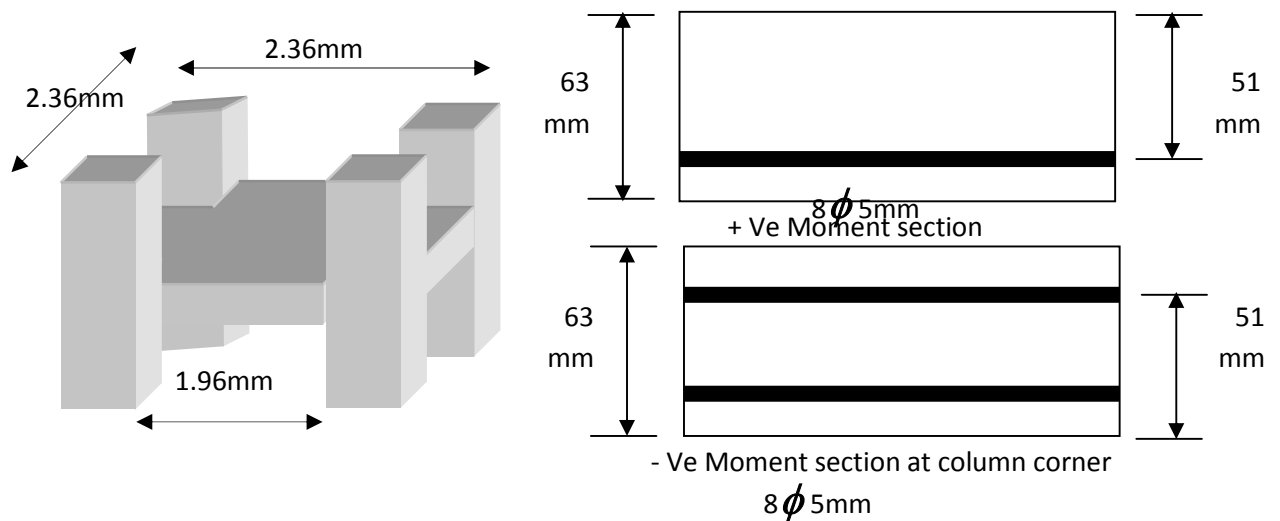





$B$	$E_c$	$f_c$	$v_c$	$f_t$	$\alpha$	$\epsilon_m$	$f_y$	$E_s$	$E_p$
$N$	$M$	$M$		$M$			$M$	$M$	$M$
$2$	$3$	$8$	$0$	$3$	$0$	$0$	$4$	$0$	$0$

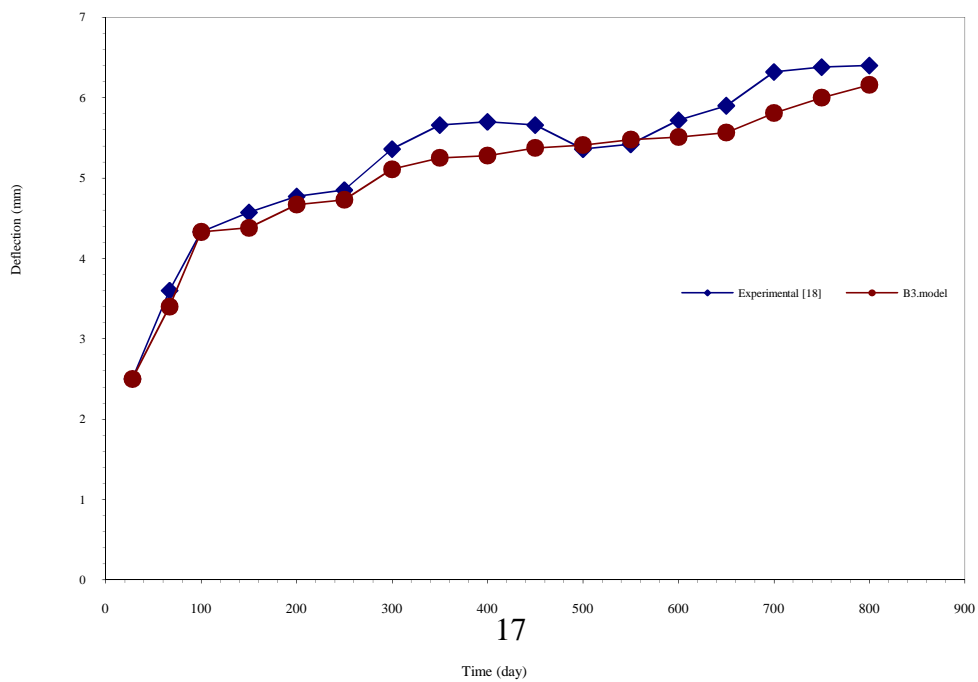

Fig (8) Variation of deflection with time.

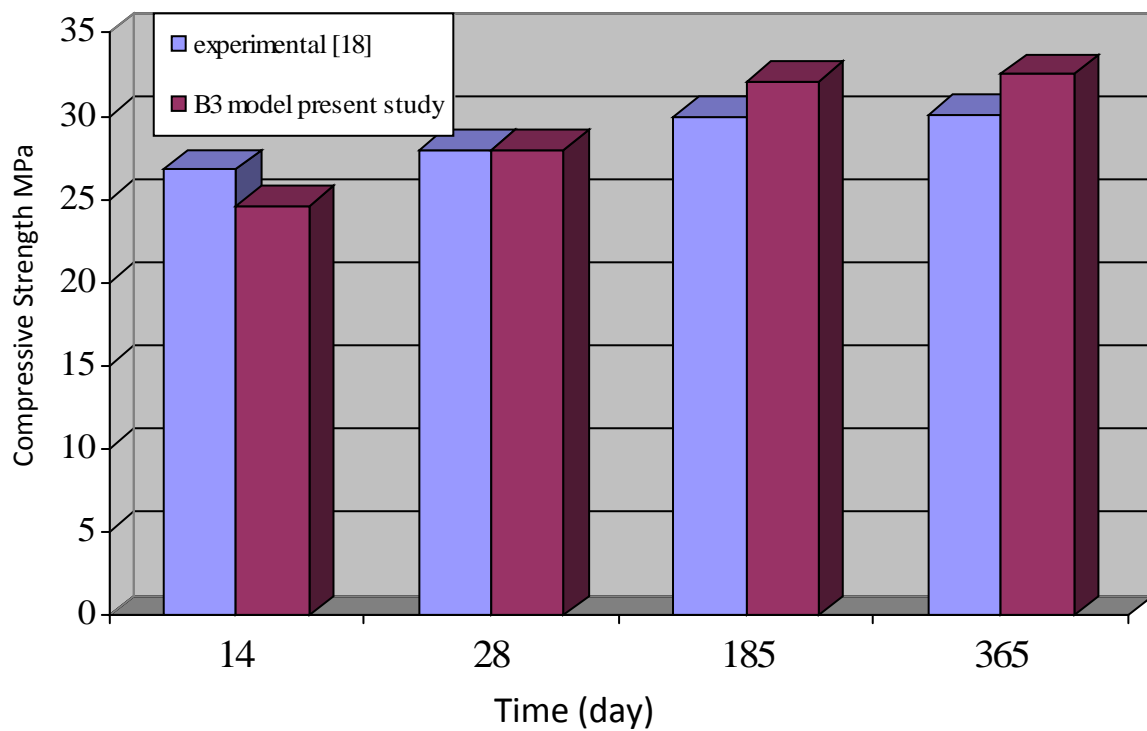

Fig (9) Variation of compressive strength with time.

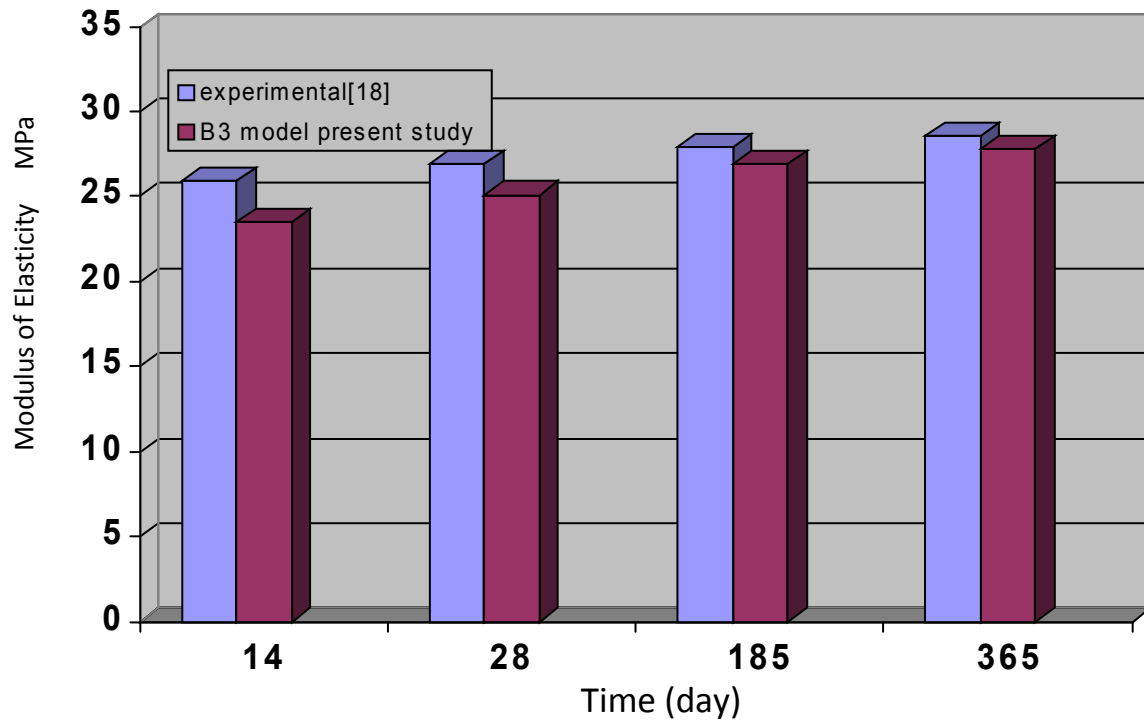

Fig (10) Variation of modulus of elasticity with time

The developed B3 model concerning the plasticity theory proved to give satisfactory results for the analysis for of materials and time dependent effects on reinforced concrete slabs . The variation of deflection, compressive strength and modulus of elasticity with time obtained by the non- linear finite element analysis are in good agreement with the experimental results.

Design procedures for such structures should incorporate the effects of long time behavior of concrete to determine both the serviceability and the ultimate safety criteria during the design life of such structures.

### References

1. Nithi, Edward, David, "FE Analysis of the Effect of Significance on Geometry and Creep", *Journal of Structural Engineering*, September 1998, pp.984-991.
2. Jason, W., Weiss, Wei Yang, and Shah, Surendra p., " **Shrinkage cracking of restrained concrete slabs** " *Journal of Engineering Mechanics*, July 1998, pp. 765-774.
3. Geis, Robert, "Four stage model for predicting creep behavior", *Journal of the Engineering Mechanics*, January 1998, pp.118-120.
4. Baweja, Sandeep, Dvorak, George, J., and Bazant, Zdenk.P. " **Triaxial composite model for basic creep of concrete**", *Journal of the Engineering Mechanics*, September 1998, pp.959-965.
5. Ghali, Amin, and Azari, "Deflection prediction of members of any concrete strength", *ACI Structural Journal*, September-October 1999, pp. 807- 816.
6. Al-Nin, H.A, "The Dimensional Dynamic and Time Dependent Finite Element Analysis of Reinforced Concrete Members", PhD Thesis, Baghdad University, 1996, 157pp.
7. Abdu-Razzak A.A., and M.A. AL- Jurmaa, " **Non Linear Material and Time Dependent Behavior of Reinforced Concrete Slabs** " *Scientific Journal Tikrit university* April 2002 ,Vol .9, No.1, pp.46-61.
8. Abdu-Razzak A.A., and M.A. AL- Jurmaa, " **Effect of mix property on time dependent behavior of reinforced concrete slabs**" under published in the technology university.
9. Huang, H.C., " **Handbook of Concrete Technology and Application** ", Springer Verlag Berlin, Heidelberg 1989.

10. Bazant, Z.P., and Wittmann, F.H., " **Creep and Shrinkage in Concrete Structures** ", John Wiley and Sons, New York, 1982.
11. Gilbert, R.I., " **Time Effects in Concrete Structures** " Elsevier Sciences Publishing Company", Inc, New York, 1988.
12. D.V., Rososky, E.H., Khor, and M.G., Stewart, Application of Statistics and Probability, Melchars and Stewart (eds.) 2000 Balkema, Rotterdam.
13. Bazant, Z.P. and Bawe, S. " **Form creep and shrinkage of reinforced concrete slabs** ", *Journal of Structural Engineering*, Vol. 12, 1986, pp.488-495.
14. Bazant, Z.P., and Chern, J.C, " **Log- double power law for concrete creep** ", *Am. Concrete Ins. Journal*, 82, 1985, pp. 665-675.
15. Hinton, E. and Owen, D.R.J., " **Finite Element Soft wear for plate and shell** ", Pine ridge press, Swansea, 1984.
16. Bahi, A. and Hu, T.H. " **Constitutive Laws of Softened Concrete in Biaxial Tension-Compression** ", *ACI Structural Journal*, Vol. 92, No. 5, 1995, pp.562-573.
17. Washa, George, W., " **Plastic Flow of Thin Reinforced Concrete Slabs** " *Journal of American Concrete Institute*, Vol. 19, No. 3, November 1947, pp. 237 – 260.
18. Gade, N. and Fu, H.C, " **Effect of High Compressive Load on the Long Term Deflection of Slabs** " *ACI Structural Journal*, July-August 1987, pp. 349- 360.

